





















1	2	3	4	5	
Kugelhahn 	Sicherheitsventil 	Pumpe 	Thermometer 	PV Puffervorlauf 	KW Kaltwasser 
Regelventil 	Entleerung 	Thermo Regelventil 	Manometer 	PR Pufferrücklauf 	WW Warmwasser 
Rückschlagventil 	Strömungsschalter 	Motor Regelventil 	Fühler 	ZV Zirkulation Vorlauf 	ZR Zirkulation Rücklauf 
Schmutzfänger 	Wärmemengenzähler 				



LME | Hydraulikschemata | Frischwassermodul 50-115 Liter mit Zirkulationsmodul 5-20kW

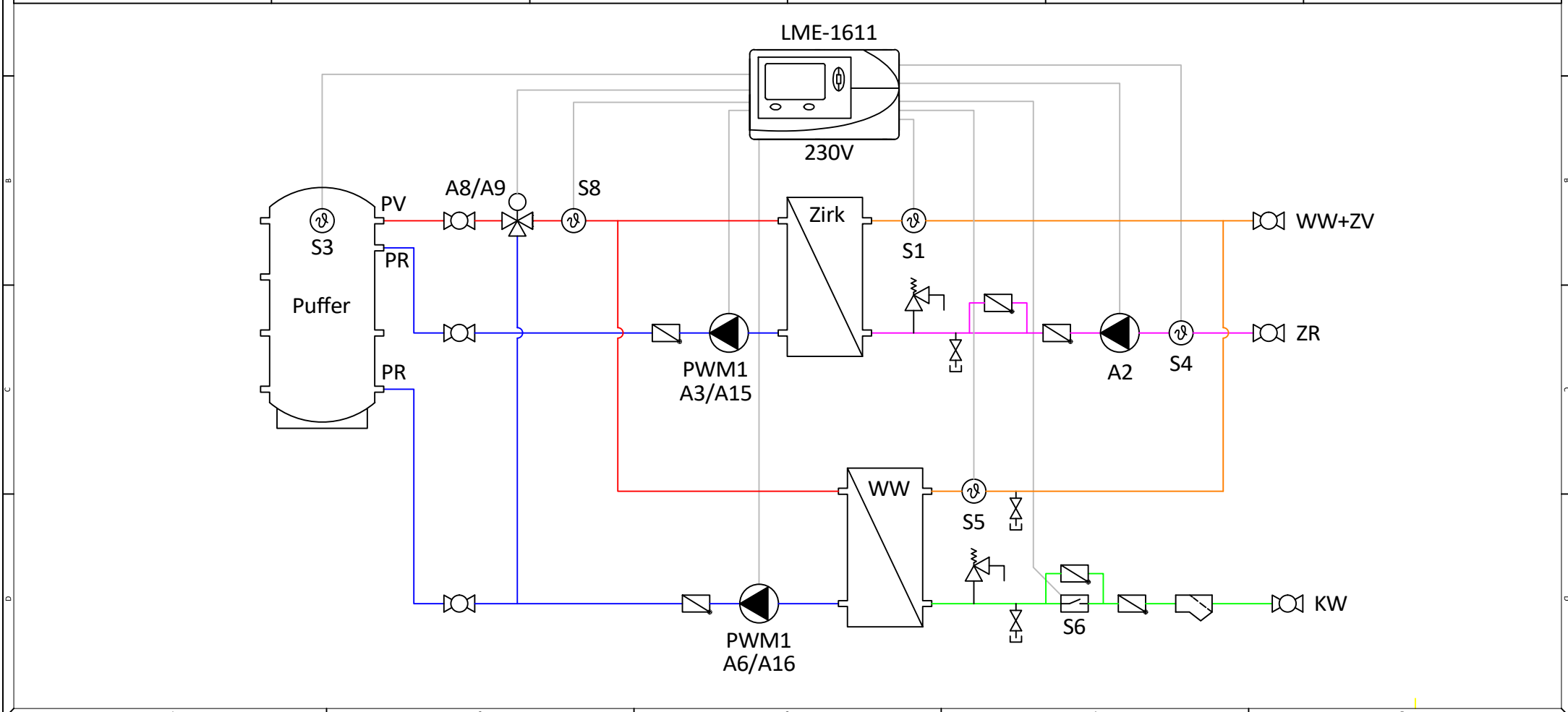

**LME** GmbH

**Ihr zuverlässiger Partner  
für Energiesparheizsysteme**



+43 (0)664-33 62 396

**LME GmbH**  
Mühlkreisbahnstraße 22  
A-4111 Walding  
www.lme.co.at